

DATASHEET

QUICK CHANGERS

v1.9

1. Datasheet

1.1. Quick Changers

Quick Changer

Name	Quick Changer I/O support – Robot Side	Quick Changer - Robot Side	Quick Changer - Robot Side 4.5A	Quick Changer - Robot Side
Item #	102326	102037	104277	109498
Version	QC-R – I/O	QC-R v2*	QC-R v2-4.5*	QC-R v3
Illustration				

* This product has been discontinued.

Dual Quick Changer

Name	Dual Quick Changer	Dual Quick Changer 4.5A	Dual Quick Changer
Item #	101788	104293	109878
Version	Dual QC v2*	Dual QC v2-4.5*	Dual QC v3
Illustration			

* This product has been discontinued.

Dual Mounting Kit

Name	Quick Changer A	Quick Changer B	Splitter*
Item #	114975	114972	114999
Version	QC-R v3	QC-R v3	v1
Illustration			

* The center hole in the splitter is intended for optional use with an M4 screw. Tighten to a maximum of 0.2 Nm to avoid damaging the splitter.

If not specified, the data represent the combination of the different Quick Changer types/sides.

Technical data	Quick Changer	Dual Quick Changer	Units
Rated payload *	25	30	[kg]
	55.11	66.13	[lbs]
Permissible force *	400	600	[N]
Permissible torque **	40		[Nm]
Repeatability	±0.02		[mm]
IP Classification	67		
Operating life (Tool change)	5.000		[cycles]
Operating temperature	From 0 to 50		[°C]
	From 32 to 122		[°F]

* See static load capacity graph below.

** See [QC Maximum Allowed Torque](#) for more details.

	Quick Changer	Quick Changer for I/O	Dual Quick Changer	Quick Changer - Dual Mounting Kit	Quick Changer - Tool Side	Units
Weight	0.06	0.093	0.41	0.06	0.14	[kg]
	0.13	0.21	0.9	0.13	0.31	[lb]
Dimensions	See Mechanical dimension section					

[QC-R V3 | DQC V3 and the QC-R V2 | QC-R V2-4.5A | DQC V2 | DQC V2-4.5A](#)

The following graph shows the load capacity that the QC-R V3 | DQC V3 and the QC-R V2 | QC-R V2-4.5A | DQC V2 | DQC V2-4.5A can handle in a static situation. The values for a situation with an acceleration of 2g are half of the static values.

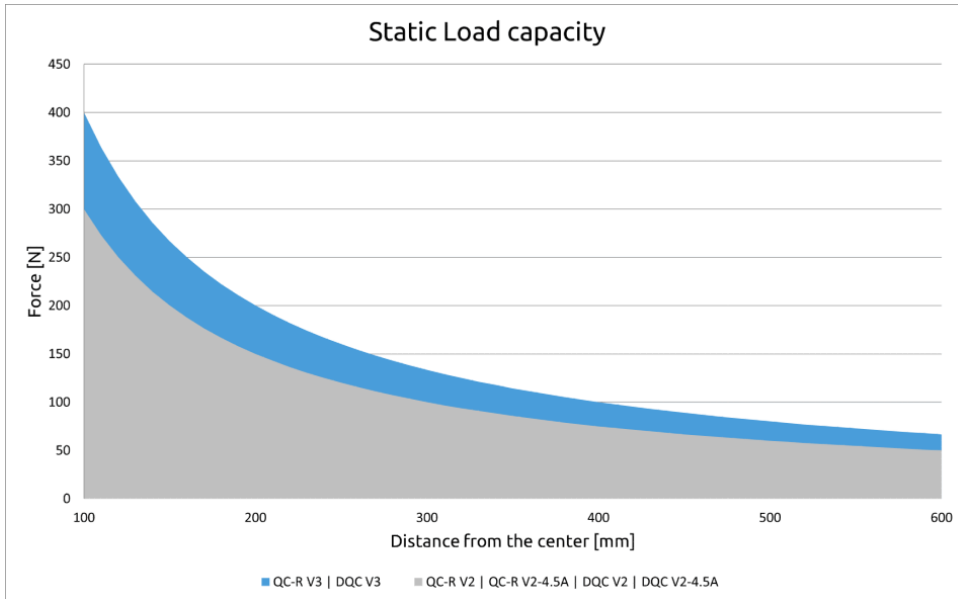

QC Maximum Allowed Torque

The maximum allowed torque applied to the Quick Changer and Dual Quick changer is 40 Nm. The picture below shows the coordinate system from where the maximum allowed torque is calculated.

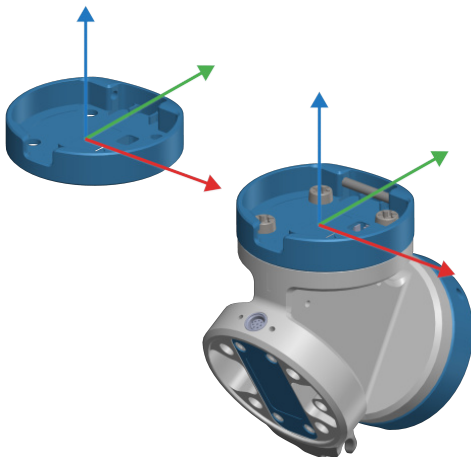

1.2. Quick Changers box content

Quick Changer Robot Side / Quick Changer - I/O Robot Side / Quick Changer Tool Side package content

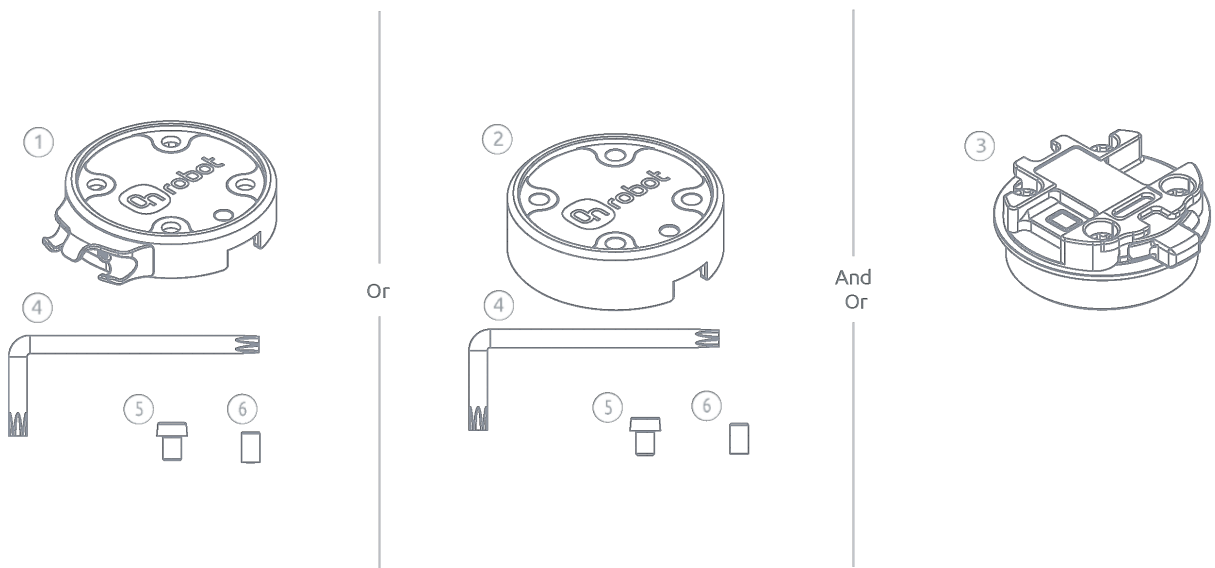

① Quick Changer Robot Side

② Quick Changer - I/O Robot Side

③ Quick Changer Tool Side

④ Torx key T30

⑤ Screw M6x8mm

⑥ Pin Ø6x10mm

* Content varies based on tool combination - See box outside sticker.

Dual Quick Changer package content

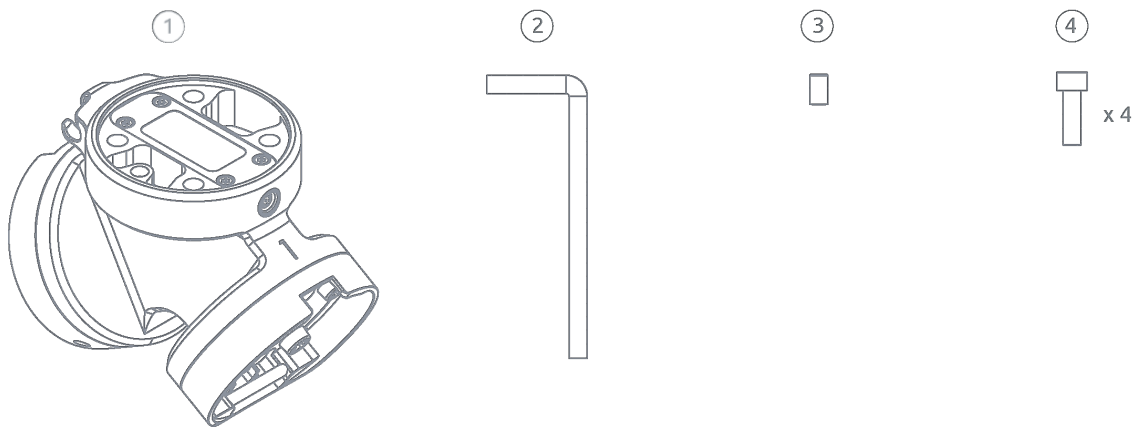

① Dual Quick Changer

② Allen 5 mm key

③ Pin

④ M6x18 mm Screws

Dual Mounting Kit package content

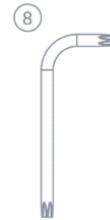
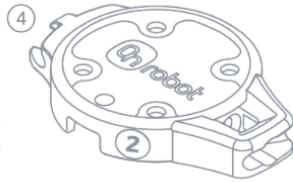
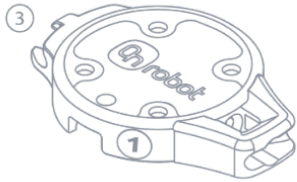

1 M8 to M12 Cable

2 M8 to M8 Cable

3 Quick Changer 1

4 Quick Changer 2

5 Splitter 2x M8 to 1x M8

6 Screw M6x8mm

7 Pin Ø6h8x10mm

8 Torx T30 Key

1.3. Quick Changer - Robot Side

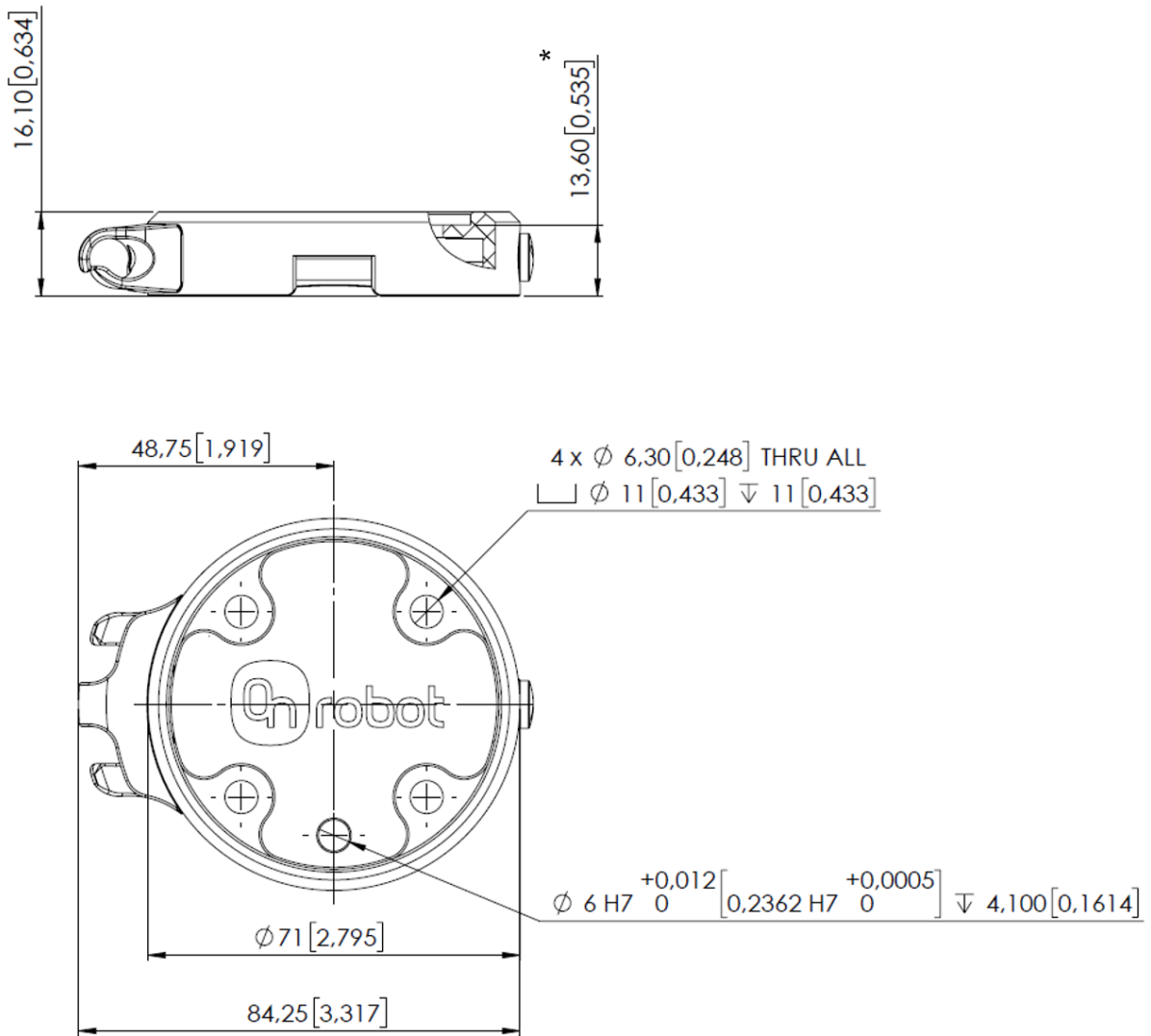

* Distance from Robot flange interface to OnRobot tool.

All dimensions are in mm and [inches].



NOTE:

The cable holder (on the left side) is only required with the long cable.

1.4. Dual Quick Changer

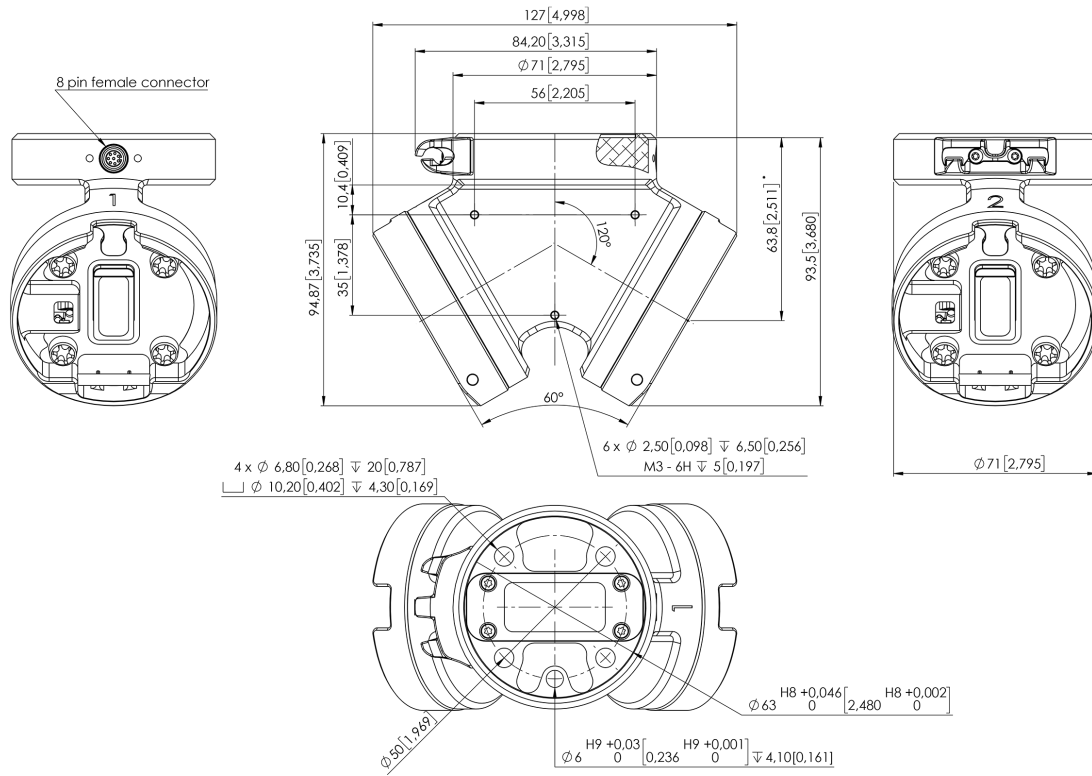

* Distance from Robot flange interface to OnRobot tool
 All dimensions are in mm and [inches].

1.5. Dual Mounting Kit - Splitter

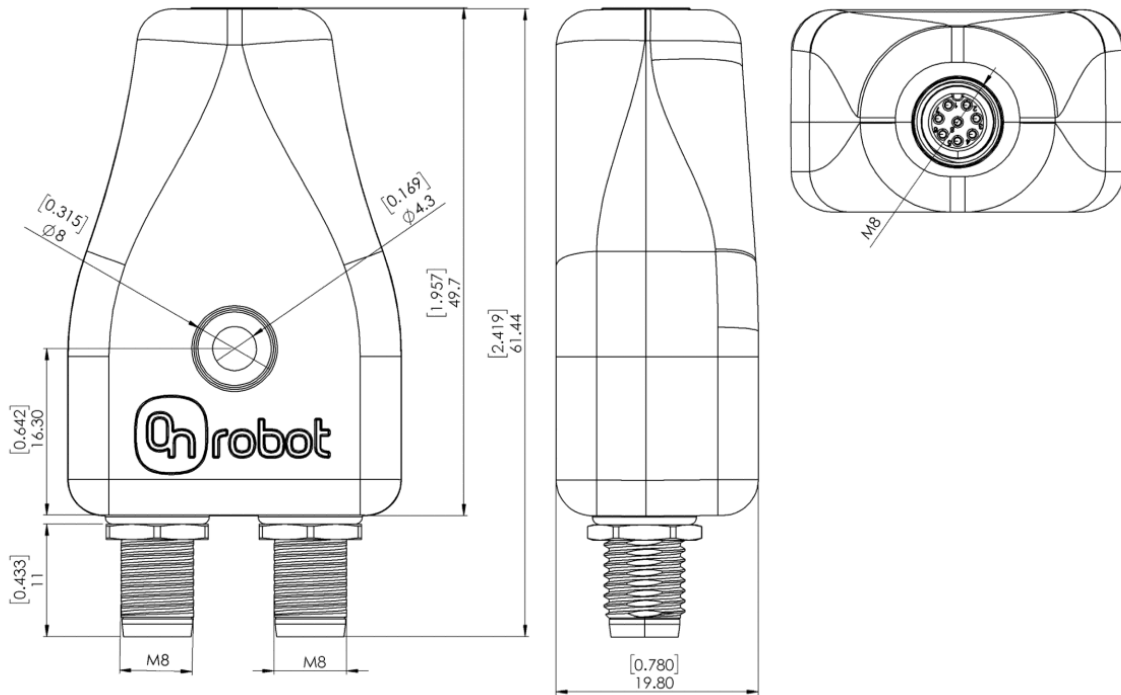

All dimensions are in mm and [inches].



NOTE:

The center hole in the splitter is intended for optional use with an M4 screw. Tighten to a maximum of 0.2 Nm to avoid damaging the splitter.

1.6. Quick Changer for I/O - Robot Side

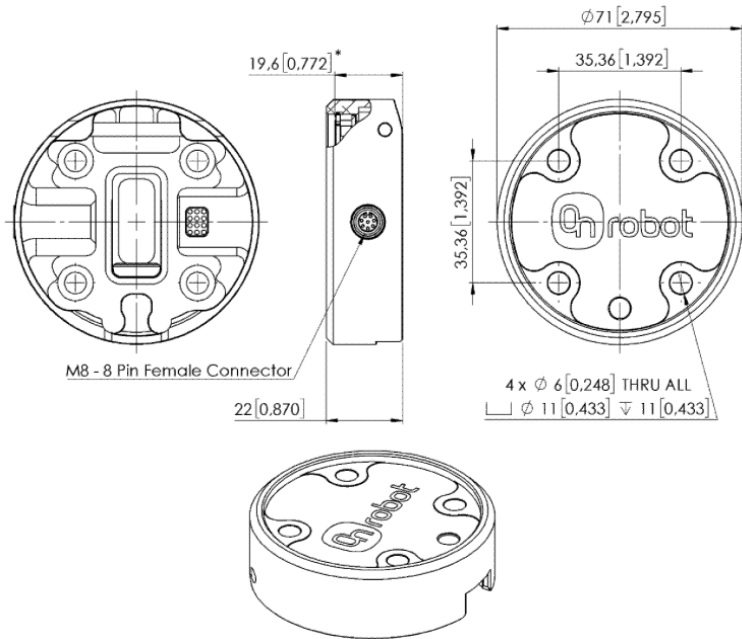

* Distance from Robot flange interface to OnRobot tool
 All dimensions are in mm and [inches].

1.7. Quick Changer - Tool Side

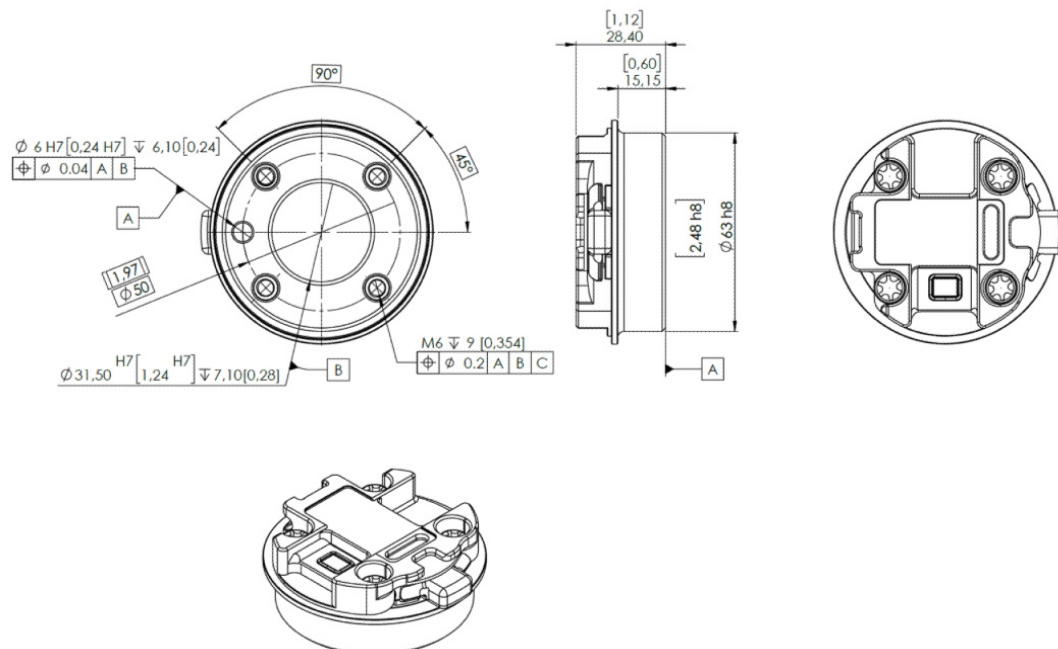

All dimensions are in mm and [inches].